



Since 1983 Dekko Engineering, otherwise known as PENT, has been recognized as a leader in the design and manufacture of innovative power distribution solutions for the office furniture industry. With headquarters in northeastern Indiana, Dekko Engineering supplies products to office furniture manufacturers worldwide, from manufacturing facilities in Indiana, Iowa, Wisconsin, and Mexico.

By providing strong engineering support and closely working with other Group Dekko companies, Dekko Engineering can quickly move from initial concept to final design. All necessary testing can be completed in-house at our UL Client Agency certified Dekko Technical Center. Customers can select from a large variety of standard catalog parts or, for large volume items, work with us to develop a custom solution that fits their specific needs.

Building strategic partnerships with our customers has allowed us to provide low total cost, high quality solutions for the office furniture industry.

Dekko Engineering
P O Box 2000
Kendallville, IN 46755
260-347-0700

For more information on the products and services that Dekko Engineering & Group Dekko provide, please visit

www.dekko.com

4-2-2 Wiring Schematic

8-Wire Shared Neutral

"2 + 2" - 2 Utility circuits, 2 dedicated

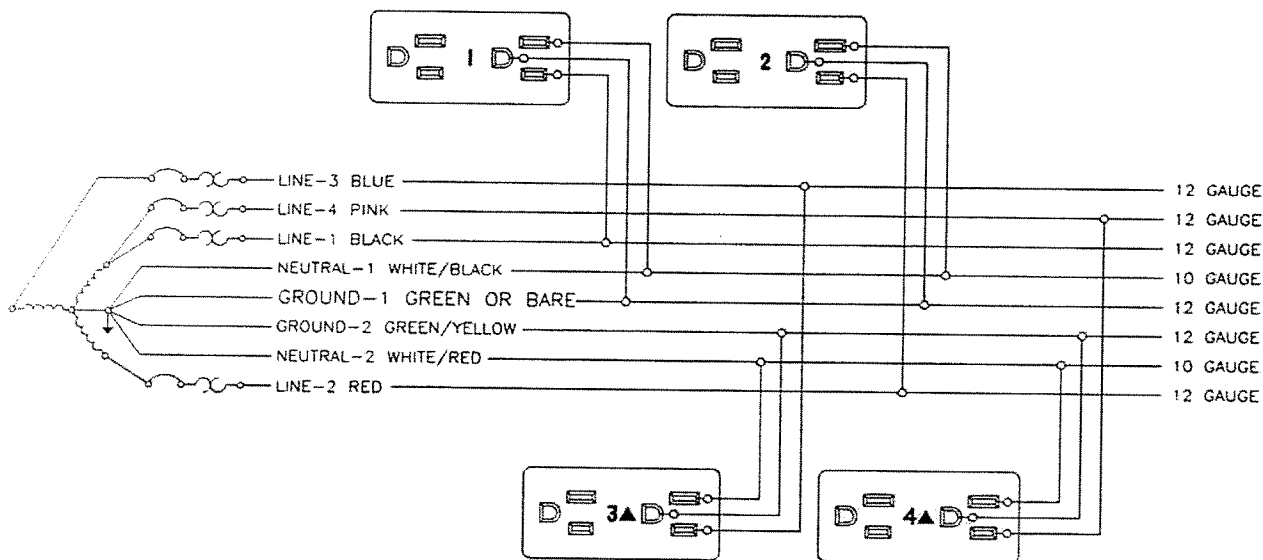

120/208V WYE
*Delta Connections & Other Receptacle
 Configurations Available Upon Request*

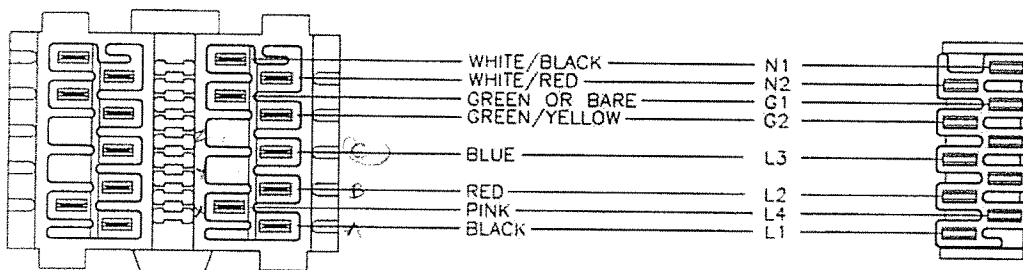

WIRING ORDER 8-WIRE
 4-2-2 (2 + 2)
 DISTRIBUTION END VIEW

WIRING ORDER 8-WIRE
 4-2-2 (2 + 2)
 PLUG END VIEW

Typical Panel Connections

Typical Three Way Panel Connection

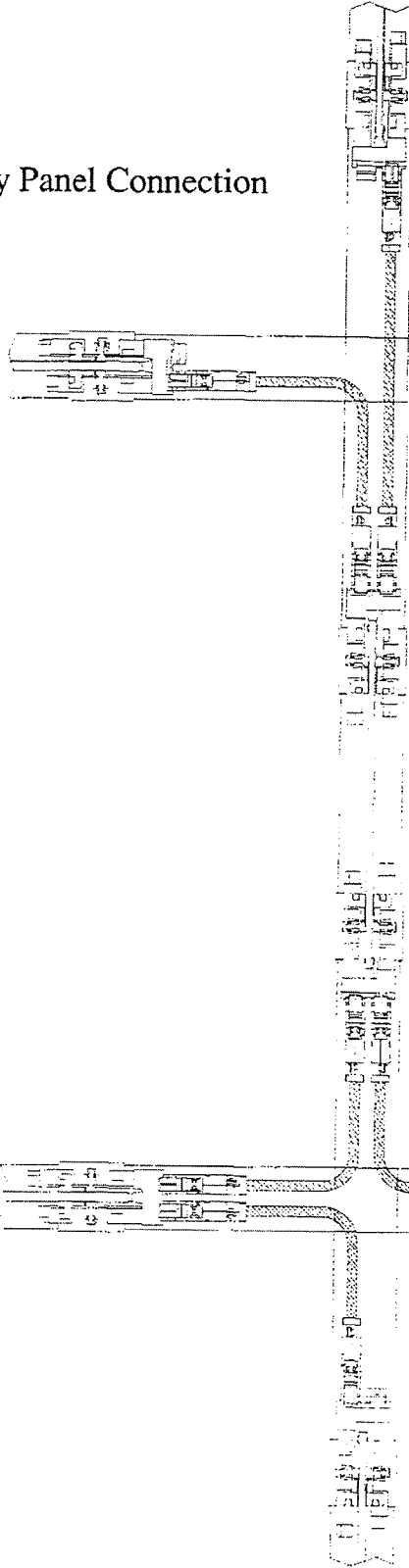

Typical Four Way Panel Connection

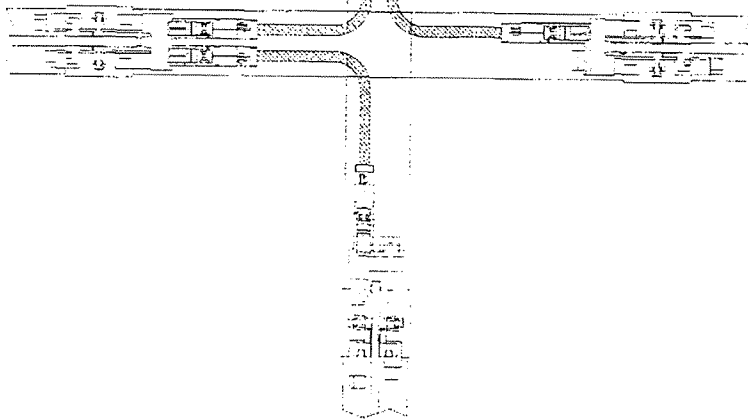

Installation Instructions

Electrical Distribution Assembly

The Electrical Distribution Assembly is mechanically attached to the panel base or table. It serves to provide point of attachment and electrical connection for duplex receptacles, flexible panel connectors, and power entry components.

1. Access covers must be removed to allow installation.
2. Mechanically attach the distribution assembly to the unit using attachment means supplied with the panel furniture system.

NOTE: Depending on the type of attachment means, it may be most convenient to attach the electrical distribution system before the furniture is assembled.

3. All unused outlets must be capped (part #580020) for a UL 183 Manufactured Wiring Harness system.

Floor Power Entry

The Floor Power Entry is used to connect the electrical distribution system to the building power network at a floor level junction box or similar device.

NOTE: Never connect components while system is under load.

1. Locate the appropriate connection point on the panel. The access cover must be removed to allow installation.
2. Pass the conduit through the opening in the access cover so the connector housing is inside the access cover next to the connection point.
3. Position the Floor Power Entry in the mounting bracket and slide it in toward the electrical distribution assembly.
4. Be sure the parts are fully seated to assure proper electrical connection and mechanical security.
5. Install attachment screws if screw type brackets are being used.
6. Replace the access cover.
7. Connection to the building wiring must be done by a qualified electrician according to national, state, and local codes (see Warning Label). Refer to the wiring schematic attached to the conduit or shown at the start of each section.

Duplex Receptacle

The Duplex Receptacle plugs into and is mechanically attached to the electrical distribution assembly. The receptacle is internally arranged to connect to the circuitry designated by the symbol on its face.

1. The access cover must be removed to allow installation.
2. Select the correct receptacle for the circuit desired at that location.
3. Position the receptacle into the mounting bracket on the electrical distribution assembly and slide it in toward the electrical distribution assembly. Be sure the parts are fully seated to assure proper electrical connection and mechanical security.
4. Install the attachment screws if screw type brackets are being used.
5. Re-install the access cover.

Ceiling Power Entry

The Ceiling Power Entry is used to connect the electrical distribution system to the building power network at an above ceiling level junction box or similar device. The Ceiling Power Entry is installed by plugging directly into an electrical distribution assembly. The procedure is similar to jumper installation and the connection point is the same.

NOTE: Never connect components while system is under load.

1. Locate the appropriate connection point on the panel or table. The access cover must be removed to allow installation.
2. Feed the open end of the power entry assembly from the bottom of the panel or table to the ceiling through the power pole or other wire way provided with the furniture system.
3. Position the power entry connector at the end of the appropriate power distribution assembly and plug them together. Be sure the parts are fully seated and latched to assure proper electrical connection and mechanical security.
4. Replace the access cover.
5. Connection to the building wiring must be done by a qualified electrician according to national, state, and local codes (see Warning Label). Refer to the wiring schematic attached to the conduit or at the start of each section.

Installation Instructions

Jumper

The Jumper is utilized to electrically connect electrical distribution assemblies.

NOTE: Electrically connected panels or tables must be mechanically connected.

1. Complete all mechanical connections between units prior to electrical connection.
2. Position the Jumper between appropriate electrical distribution assemblies. Orient the connectors and plug them together. Be sure the parts are fully seated and latched to assure proper electrical connection and mechanical security.

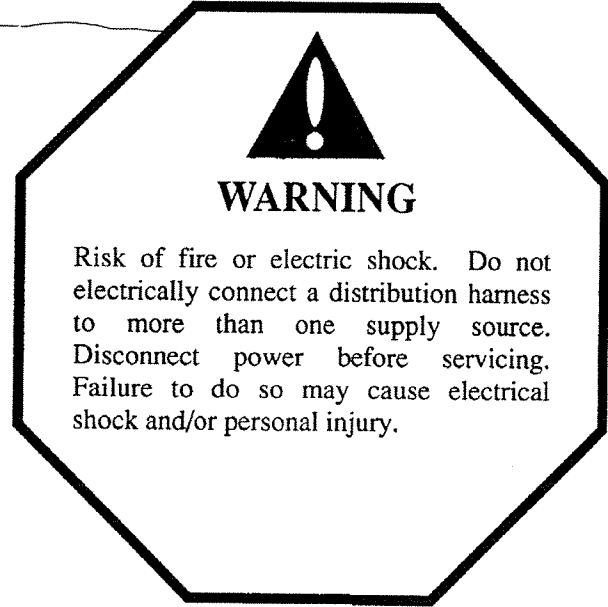

Typical Assembled System

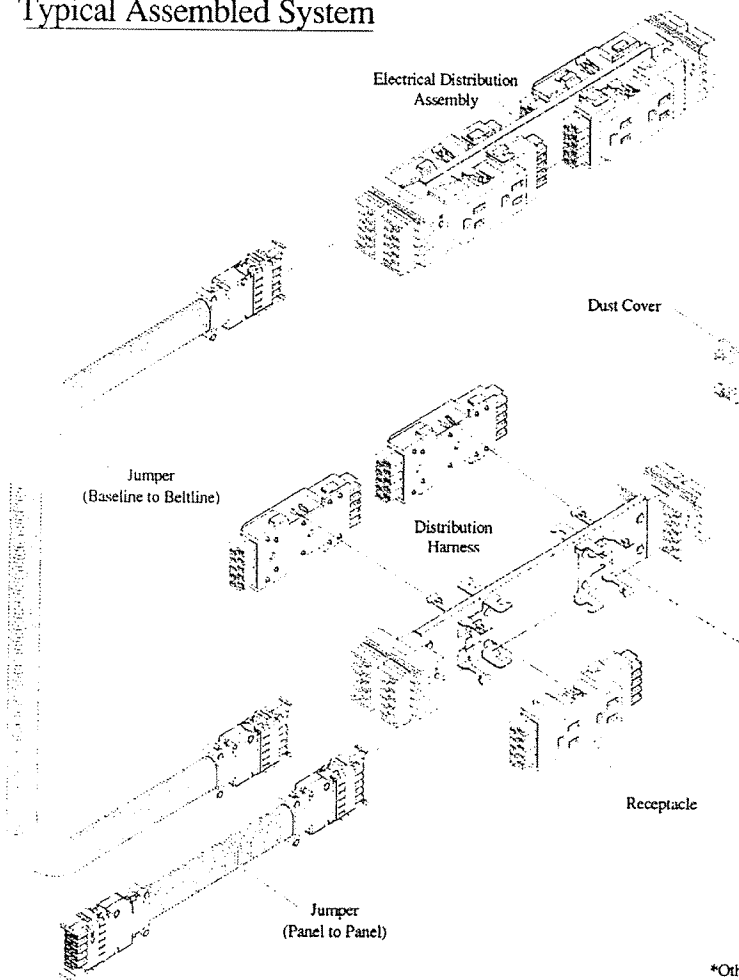

Beltline Power

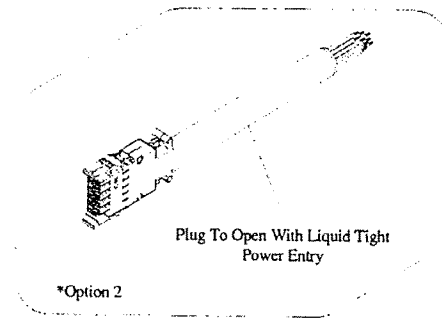

Baseline Power

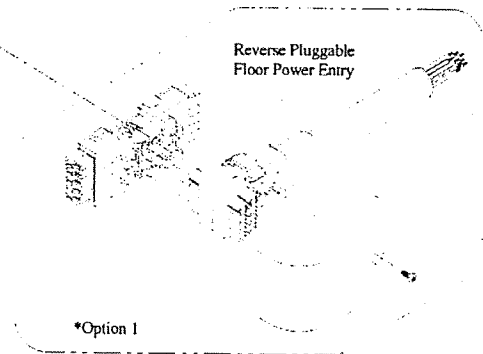

*Other Power Entry Options Available

The 8-10 System Advantage

10-Wire Version

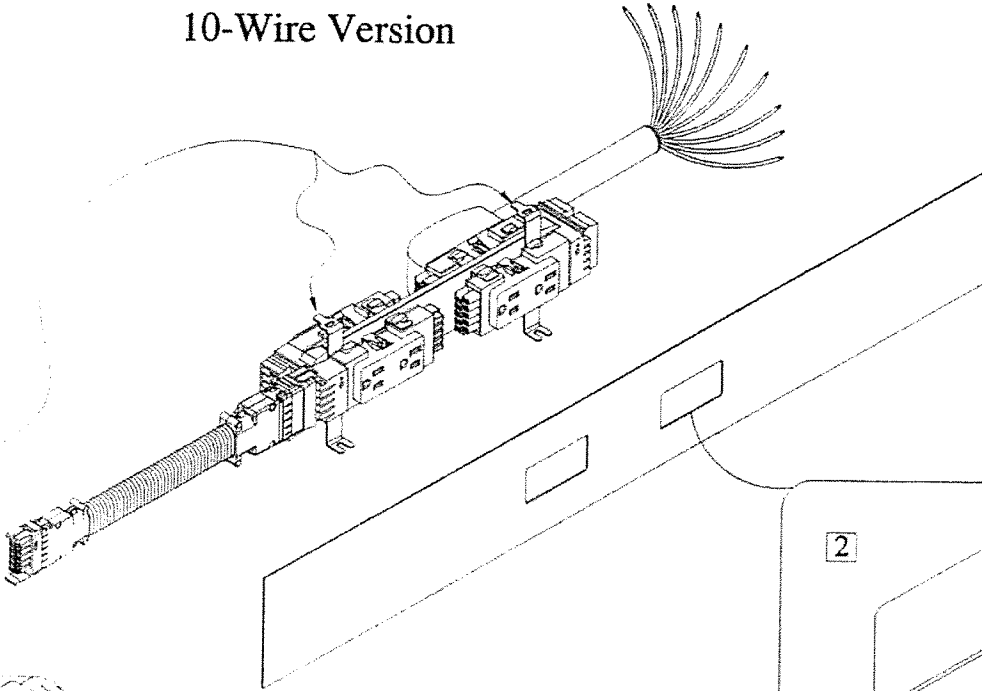

2

Receptacle cut outs are identical

EVOLVE
8-Wire Version

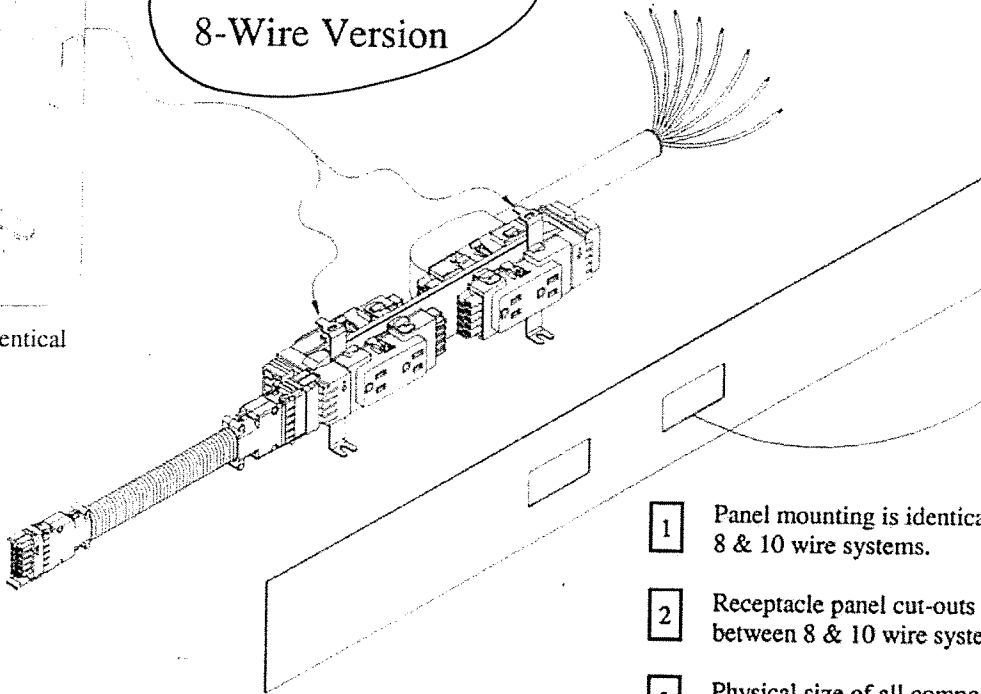

1

Panel mounting is identical between 8 & 10 wire systems.

2

Receptacle panel cut-outs are identical between 8 & 10 wire systems.

3

Physical size of all components are identical between 8 & 10 wire systems.

Mounting is identical

System Specifications

UL 1286

OFFICE FURNISHINGS

280 Series

Where Used: Modular panel systems
 Tables
 Other applications

Approvals: UL recognized and CSA certified

UL 183

MANUFACTURED WIRING SYSTEMS

580 Series

Where Used: Full wall panels
 Tables
 Underfloor / Overhead
 Other applications

System Listed for Use in Environmental Air Spaces
 (Reference NEC Code 300-22 Section C)

Approvals: UL listed and CSA certified

Configurations:

Version	8 Wire		10 Wire				
	4-2-2 Shared		3-3-2 Independent	6-2-2 Shared		4-4-2 Independent	
Lines (12 ga)	4		3	6		4	
Neutrals (10 ga)	2			2			
Neutrals (12 ga)			3			4	
Grounds (12 ga)	2		2	2		2	
Utility Circuits	3	2	2	3		3	2
Dedicated Circuits	1	2	1	3		1	2
Receptacles Per Infeed	52		39	78		52	

Receptacles: Back-to-Back duplex receptacles (up to 13 receptacles per circuit)

Power Entries: Floor and ceiling in-feeds available

Mounting: Custom mounting brackets available

Specifications: System rated at 20A (15A CSA) 3 ph (120/208v), 1 ph (120/240v)
 Receptacles are 15A & 20A

Lengths: See selection guide starting on page 9